

V20KD 2023 P2

INFINISO

INSTRUCTION MANUAL **V2** 25"

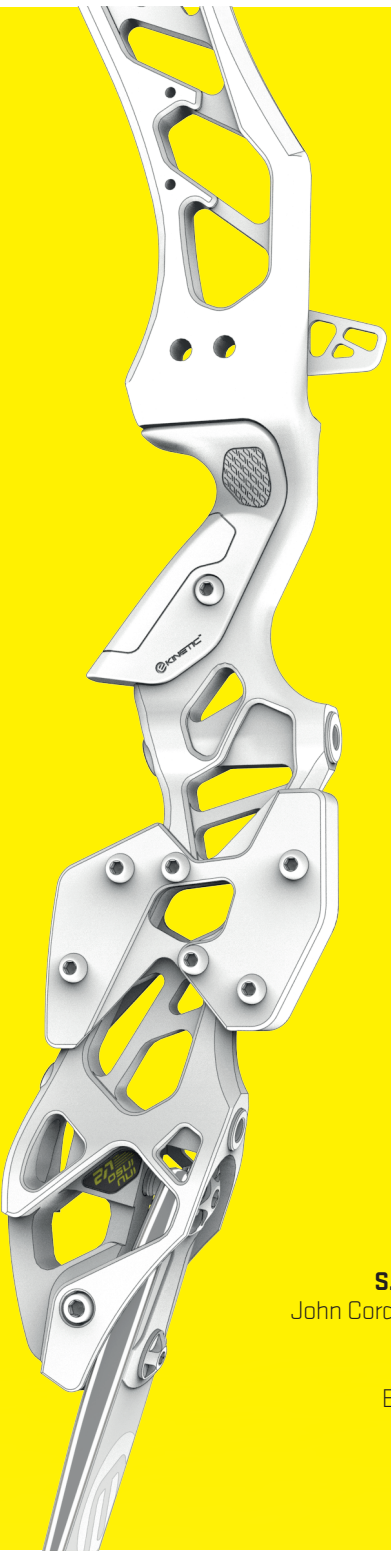

Distributed by:
S.S.A. SPORTING GOODS NV
John Cordierlaan 15, 8400 Oostende, Belgium
Tel: +32 50 42 72 40
Fax: +32 50 42 42 45
E-Mail: info@ssa-archery.be



BOW OVERVIEW

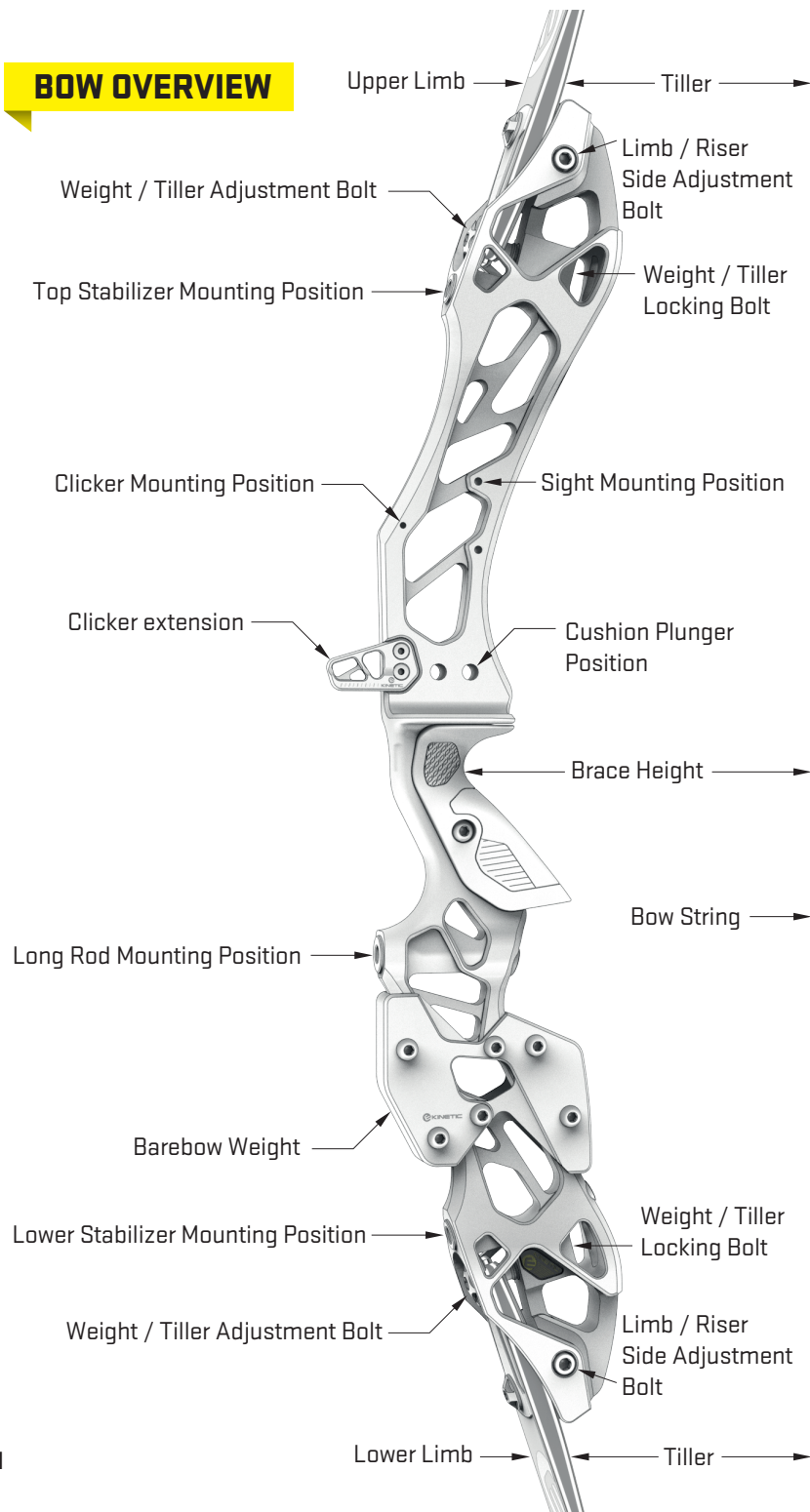

LIMITED LIFETIME WARRANTY

Your Kinetic Invinso V2 bow is warranted to be free of defects in materials and workmanship for the lifetime of the original owner when purchased from an Authorized Retailer. This warranty includes all bow parts, except the adjusting screws and cosmetic appearance.

SAFETY FIRST

In order to ensure your personal safety and the safety of those around you, it is necessary for you to read, understand and follow all of the warnings and safety guidelines before you begin using or working on your bow or any other archery equipment used with the bow.

WARNING: This bow is strictly intended for recreational use only.

WARNING: Kinetic Archery shall not be liable for injuries suffered or caused by misuse, unsafe or improper arrow and bow combinations or for injuries sustained when using an altered or modified bow or by unconventional use.

WARNING: Never work on or attempt to shoot your bow while on medication or while using drugs or alcohol which may impair your judgment, physical abilities or reflexes. Doing so can result in damage to the bow, serious injury or even death.

WARNING: Your bow is a precision instrument. It requires specific care and handling to maintain and achieve maximum performance. Accordingly, Kinetic recommends that all maintenance and repair of your bow be performed by an authorized retailer. Failure to comply with this warning may void your warranty, cause damage to your bow, serious injury or even death. Kinetic will not assume any liability if this warning is ignored.

BEFORE SHOOTING YOUR BOW

WARNING: Be sure to take the following actions to carefully inspect the condition of your bow each time before use:

- Inspect the condition of the bowstring
- Inspect the condition of the string servings and nocking point
- Inspect that the limbs and riser are in proper condition and orientation
- Always keep your bow string waxed
- Inspect the condition of the arrows, nocks, fletching, arrow rest and bowsight

WARNING: A damaged string will adversely affect the performance of your bow. This can result in further damage to other bow components and may cause serious injury to yourself and those around you. Any damaged bow parts or accessories should be reported to your authorized retailer for inspection or replacement.

WARNING: Always exercise extreme caution when handling sharp objects around the bow's string. A string that is cut or frayed should be replaced immediately. A cut string can result in instantaneous separation and may cause serious injury to yourself and those around you.

WARNING: NEVER DRY-FIRE YOUR BOW.

To dry-fire means to draw and release the bowstring without an arrow nocked to the string. Dry-firing your bow can drastically reduce its life expectancy and can cause immediate damage to the bow/limbs and possibly serious injury to yourself and those around you.

WARNING: Always shoot the recommended minimum arrow weight. Do not shoot an arrow weighing less than six grains (0.4 grams) for every pound of draw weight. For example, if your bow is set at 30lbs do not shoot an arrow weighing less than 180 grains (12 grams). Shooting an arrow below six grains per pound of the bows draw weight can cause damage to your bow/limbs and may cause serious injury to yourself and those around you.

Damage caused by shooting an arrow that is too light will not be covered under warranty. Shooting an underweight arrow has an effect similar to that of a dry-fire and may cause serious injury to yourself and those around you. If you are unsure about the arrow compliance to your bow, contact your authorized retailer or the arrow manufacturer.

WARNING: Shoot arrows with a suitable length to prevent the arrow from falling off the rest when drawing your bow. Always follow the inspection recommendations provided by the manufacturer of your arrows. Immediately discard any dented, split, splintered or otherwise damaged arrows. Replace cracked, damaged or broken nocks. NEVER SHOOT A DAMAGED ARROW. Shooting a damaged arrow may cause serious injury to yourself and those around you.

SHOOTING YOUR BOW

WARNING: ALWAYS BE SAFE!

Never shoot an arrow straight up.

Never draw or attempt to shoot your bow unless you are certain that no part of the bow can come into contact with another object during the shooting process. Never aim or point a drawn bow at another person or object you do not intend to shoot.

Always use the correct shooting form to avoid arm injury caused by the string.

WARNING: ALWAYS BE SURE OF YOUR TARGET!

Make sure that there are no people, animals, buildings, roads or other objects behind or near your target. Ensure that your backstop is large enough to catch

a stray arrow and thick enough so that the arrow will not be able to penetrate completely through it. When shooting with others, never retrieve arrows or allow others to retrieve arrows until all arrows have been shot and the shooting lane is clear.

STORING AND MAINTAINING YOUR BOW

WARNING: Never expose your bow to excessive heat or prolonged moisture. Avoid storing your bow for extended periods of time in places such as in a garage, attic, or in the trunk of a vehicle as this can subject your bow to extreme heat or moisture. Doing so can cause damage to your limbs, string and other parts of the bow which may not be covered under the manufacturer's warranty. Should your bow become exposed to moisture, make sure it is completely dry before you store it. Make sure to keep your bow (especially the riser) clean and free from dust. If your bow is wet, dry it by using a soft cloth. Do not heat dry the limbs!

Avoid the use of solvents, sprays or cleaners such as mineral spirits or acetone on or around your bow as these can adversely affect the finish. Regularly check the condition of screws and bolts, replace once they begin to wear out.

BOW LENGTH: RISER AND LIMB FITTING

In order to properly assemble the limbs with the riser, you will need to push the ILF detent part from the limb into the appropriately sized slot on the riser until you hear a click.

Kinetic Length of Riser	Long Limbs	Medium Limbs	Short Limbs
25 Inch	70 Inch	68 Inch	66 Inch

BRACE HEIGHT

Brace height is the horizontal distance between the grip and the bowstring. Changing the brace height does not affect the draw weight but can significantly affect bow performance. A higher brace height will decrease velocity while a lower brace height will increase velocity.

Kinetic Length of Riser	Long Limbs	Medium Limbs	Short Limbs
25 Inch	21.5~24cm	21~23.5cm	20.5~23cm

TILLER & DRAW WEIGHT ADJUSTABILITY

To adjust the tiller and bow weight, you first need to loosen the weight/tiller locking bolt with the Allen key (photo 1). Use the Allen key to turn the weight/tiller adjustment bolt clockwise to increase bow weight and counter clockwise to decrease bow weight (photo 2). When the correct poundage is set, tighten the locking bolt located at back of the riser (photo 1). It is best to adjust tiller and weight while the bow is unstrung.

Photo 1



Photo 2



When adjusting the tiller and bow weight, do not exceed the recommended turns out from the maximum position (photo 3)
 Maximum opening: 3 complete turns starting from the maximum position (photo 4)
 and it is recommended to shoot with a more closed position. (photo 3)

Photo 3

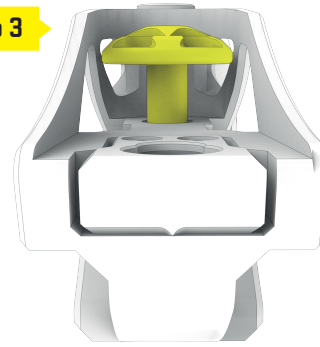
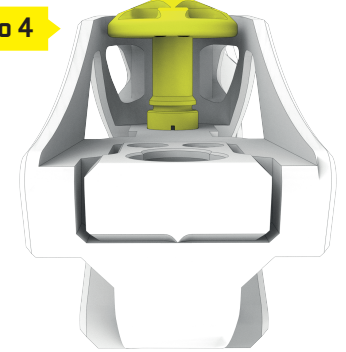

Photo 4



LIMB/RISER ALIGNMENT

Before adjusting the alignment of the riser, first check the center string position towards the riser. You can adjust the centershot without unstringing your bow.

- To adjust limb position to the left, loosen the right side adjustment bolt (photo 5) and tighten the left sided one till the limb is centered.

Photo 5

